

Correct moving orientation

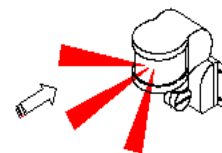

incorrect moving orientation

SensLights Model Specification	SLL 2348A Corner Motion Sensor
Power Supply	100~130V/AC 220~240V/AC
Power Frequency	50 ~ 60Hz
Rated Load	1200W(220~240V/AC) incandescent bulb (resister-load) or 300W fluorescent load
Ambient Light	<3Lux ~ Sunshine (adjustable)
Sensing Angle	220 degrees
Sensing Distance	24° C < 12 meters
Time Delay	8 sec~ 7 Minute
Work Temperature	-20 ~ +40 °C
Power Consumption	0.45 w (working) 0.1 W (static)
Installation Height	1.5~ 2.5m
Weight	170g
Detection Moving Speed	0.6-1.5m/s
Working Humidity	<93 % RH
IP	44
Illumination Location	Gate, backyard, garage, stairs, balcony, fence gate etc..
Notes	1. Avoid sunshine or being against draft outlet of air-con and vent for the installation location.



SLL2348A INFRARED SENSOR Instruction

SENSOR SWITCH! SensLights

This product is a new energy-saving lighting switch, which adopts two high sensitivity detectors, integrated circuit and SMT technology; it gathers automatism, convenience, safety and energy saving, etc. The wide detection is comprised by right and left service field; it utilizes body infrared rays as signal control source to start the load when human enters detection field; the sensor can identify day and night automatically. It is used widely and easy to install; it has the power and detection show functions.

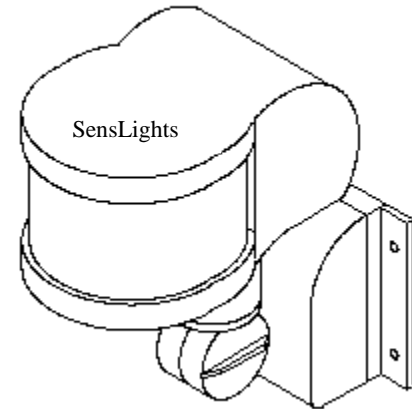

Technology reference

Power source: 220V/AC~240V/AC Related load:
110V/AC~240V/AC 1200W (220V/AC~240V/AC)
Power frequency: 50~60Hz 3000W (220V/AC~240V/AC)
Control light: <3LUX~sunshine light 800W (110V/AC~130V/AC)
Working time: min: 8sec; 3sec 1500W (110V/AC~130V/AC)
Max: 7min; 2min Working temperature: -20~40; æ
Detection range: 220degree Working humidity: <93%RH
Detection distance: 11m max (<24; æ) Power consumption: 0.45W (static 0.1W)
Installation height: 1.5m~2.5m Detection moving speed: 0.6~1.5m/s

Function

- The detection distance can be adjusted: The detection distance is short if you press down the switch, otherwise it is long;
- Can identify day and night automatically: The ambient light in which LX48A works can be adjusted freely, when you turn it to the sunshine (largest), it can work day and night; If you turn it to moon (smallest) it only can work in the light below 3LUX. Please refer to the testing way about the adjustment
- Power and detection indication: The indicator lamp flash one time each 4sec after switching on the power, it can flash 2 times each 1sec after receiving the Induction signals. So it can show if the detector and power is normal;
- Time-delay added continually: When it receives the second induction signals after the first, it should compute time once more on the rest of the first time-delay basis.
- Time-delay adjustment: The working time-delay can be adjusted according to the customer desire, the minimums time is 8sec; 3sec, the maximum is 7min; 2min.
- Locking function: during working, sensor will keep load lighting when power is shuttled off 2 seconds and then on. And shut off the power for 4 seconds and then on, sensor will resume automation.

Installation (see the following diagram)

- ✎ Shut off the power;
- ✎ Twist open the screw on the base-lid, pull on the wiring hole, put the power and load wire into the base-lid;
- ✎ Fix the base-lid with the dilatibility screw on the selected installation position;
- ✎ Put the power and load wire into the sensor according to the indication diagram;

Fix the sensor on the base-lid, twist the screw tightly then you could electrify it to test;



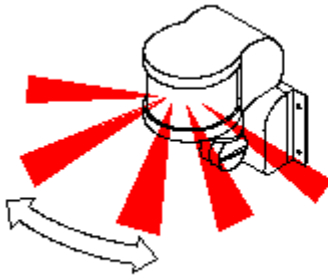

Correct moving orientation

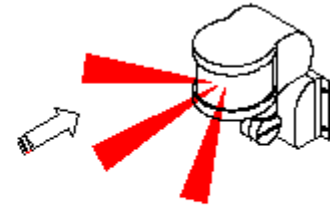

incorrect moving orientation

Connection-wire diagram

Test SensLights

- Turn the light control knob anti-clockwise to the largest; turn the time knob clockwise to smallest.
- Turn on the power, the controlled load should not work, and the indicator lamp flashes once every 4sec; the load would work within 5~10sec and the indicator lamp flashes twice every second. If there are no induction signals, the load should stop working within 5~30sec, the indicator lamp should resume to flash 1 time each 4sec;
- Sense it again 5-10sec later after the load goes out, the load should work and the indicator lamp flash 2 times every 1sec, the load stops working within 5-15sec;
- Turn the LUX knob to the smallest anti-clockwise. If you test it in the ambient light beyond 3LUX, sense it, the load shouldn't work after the load stop working; if you cover the detecting lens with opaque object (towel etc), the load should work. Under the condition of no sense signals, it is normal for the load to stop working within 5-15sec.
- Attention: there must be 5sec interval between the second sense and the first sense when the load stop working, while there needing be interval when it inducts continually during the load doesn't stop working.

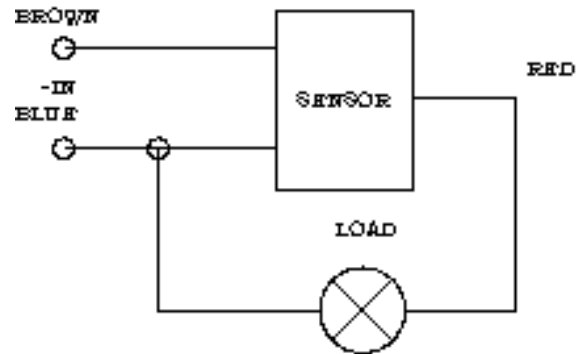

Note:

- Electrician or experienced human can install it;
- The unrest objects can't be regarded as the installation basis-face;
- There is no hinder or unrest objects effecting detection in front of the detection window;
- Avoid installing it near temperature alteration zones, for example: Air condition, central heating etc;
- Please don't open the case for your safety if you find the hitch after installation.

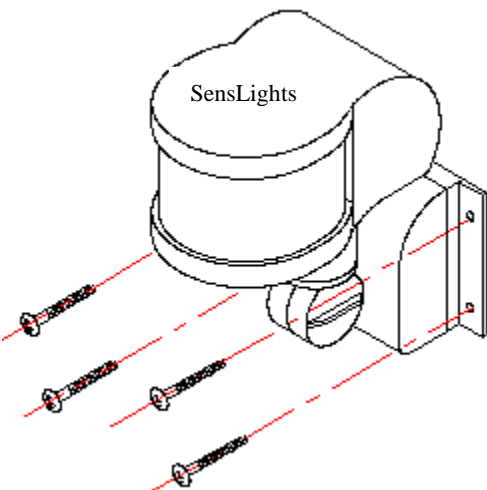

MULTITASKING CORPORATION



SOME PROBLEM AND SOLVED WAY

- **The load doesn't work:**
- Check the power and the load;
- If the indicator lamp flash 1 time every 4sec;
- If the load is good;
- If the indicator lamp quicken to flash after sense.
- Please check if the working light you set corresponds with the ambient light
- **The sensitivity is poor:**
- Please check if there is any hinder in front of the detection window that effect to receive the signals;
- Please check the ambient temperature;
- Please check if signal source is in the detection fields;
- Please check the installation height
- If the moving orientation is correct.
- **The sensor can't shut off the load automatically:**
- If there is continual signal in the detection field;
- If the time-delay is set to the longest;
- If the power corresponds with the instruction required;
- If the temperature change near the sensor, (air conditioner, central heating etc).
- Check it if it is in locking conditions.

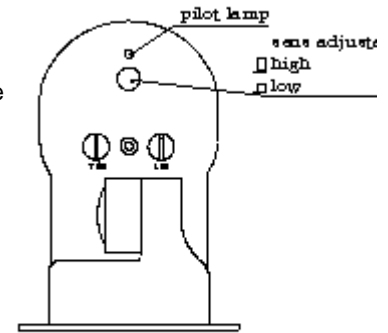

Wall Mount

Top View



Side View

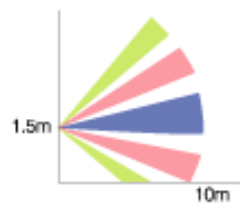

Top View

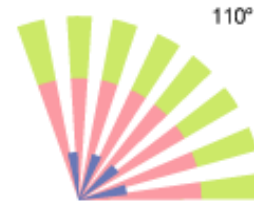

Side View

